

# EXHIBIT DISPLAY RULES AND REGULATIONS

Display Rules and Regulations have been in existence since trade events first began. Most individuals recognize the need for some limitations but may have never taken the time to determine the intent of each rule, why they were written, what they are expected to accomplish and, most important, how an exhibit can use them effectively.

The tenant on which all show management is based can be summed as follows:

“All exhibitors are equal regardless of size and should be given an equal opportunity, within reason, to present their product in the most effective manner to the audience.”

Event Management must establish rules or guidelines to make this possible while allowing the greatest flexibility within each exhibit. Remember, Event Management wants all exhibitors to be successful.

The exhibitor’s responsibility can be summed up far more simply:

“Be a good neighbor.”

With these thoughts in mind, please review the rules and regulations outlined on the following pages. Each section begins with the actual rule or guideline and is followed by the intent which is of major importance. By recognizing the intent, exhibitors can be reasonably sure they will always be “a good neighbor.”

Exhibitor Appointed Contractors (EAC’s), Booth Builders and General Contractors must submit their Architect Package (i.e. structure, electrical, plumbing etc.) to the Clark County Department of Building & Fire Prevention in order to obtain permits for double decker booths or those booths over 7,500 square feet. The Architect Package must include a signature or stamp of a reviewing structural engineer confirming that the double decker booth has been properly engineered, as well as a signature of an authorized official of the exhibit building company indicating that the structure is built in compliance with the details and specifications set forth on the drawings. For questions, or to schedule an inspection, contact the Clark County Department of Building & Fire Prevention at 702-455-8040 or email [inspchedule@ClarkCountyNV.gov](mailto:inspchedule@ClarkCountyNV.gov).

In addition, temporary buildings or structures, such as reviewing stands, grandstands, sheds or other miscellaneous structures, shall not require a permit, construction document approval or building permit issuance provided such structures are not erected or used for longer than six (6) months and meet all of the following criteria:

1. Single story
2. Total occupant load of 1,000 persons or less
3. Covering a maximum area of 7,500 square feet

**Important Note: Peninsula and Island Booths on Level 1 (booths J7200-J11200) cannot exceed a height of 12 feet. Due to the ceiling height of 12 feet, double decker booths are not permitted on Level 1.**

**Floor Covering: All exhibit space must be carpeted or have a fire-resistant covering. Any floor covering left adhered to the exhibit floor must be removed at the exhibitors’ expense.**

## TYPE A – STANDARD BOOTH

### DEFINITION:

One or more standard units in a straight line.

### DEPTH:

All display fixtures over 4'/1.22m in height and placed within 10 lineal feet/3.05m of an adjoining exhibit, must be confined to that area of the exhibitor's space which is within 5'/1.52m of the backline.

### HEIGHT:

All booths will be confined to a maximum height of 8'/2.44m.

Any type of flags, banners or structure must not exceed the maximum height of 8'/2.44m. Also, no part of the booth is permitted to be in the aisles.

### INTENT:

Each exhibitor is entitled to a reasonable sightline from the aisle regardless of the size of his exhibit. Exhibitors with larger space (30 lineal feet/9.14m or more) should also be able to effectively use as much of the total floor space as possible, as long as they do not interfere with the rights of others. The limitation on display fixtures over 4'/1.22m and within 10 lineal feet/3.05m of a neighboring exhibit is intended to accomplish both of these aims.

Any portion regardless of an exhibit extending above the 8'/2.44m high draped booth background will detract from the overall impact of the exhibit directly behind that booth regardless of how the rear of the offending exhibit is

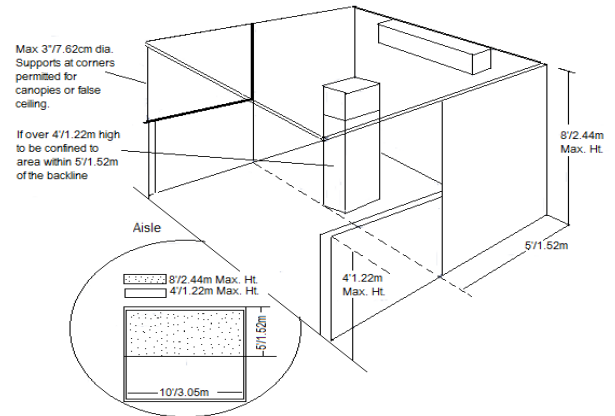

finished.

### PLEASE NOTE THE FOLLOWING:

- Canopies are not permitted.
- Cross aisle displays pertaining to standard inline or peninsulas are not permitted. Cross aisle displays are only allowed if you take 2 full Island booths exceeding over 2,000 sq. ft. per island.
- Space dimensions shown on the floor plan are from center line of booth equipment such as side rails and/or back drape. Exhibit structures must be constructed to allow sufficient tolerance on each side for this equipment and for utility service at rear of booth.
- Only pavilions may go above the 8'/2.44m height restriction. Any type of signage cannot cross the aisles. Single booths may not go above the 8'/2.44m height restriction. Canopies cannot have flags. In addition, no flags can hang in the aisle.

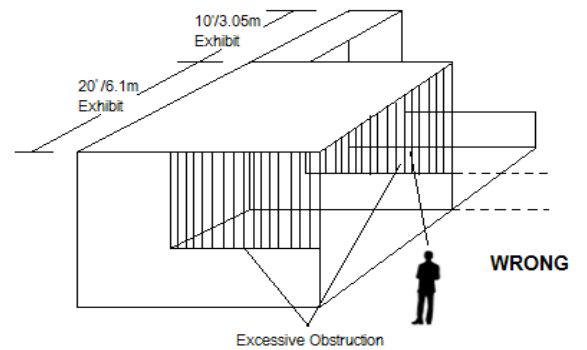
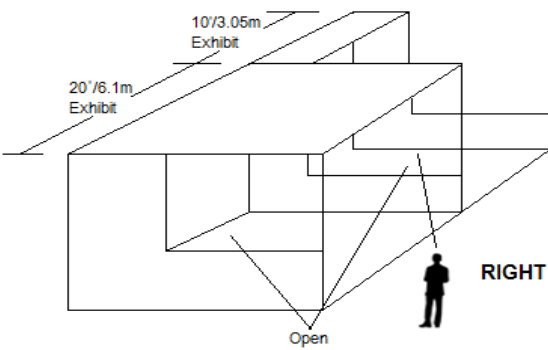
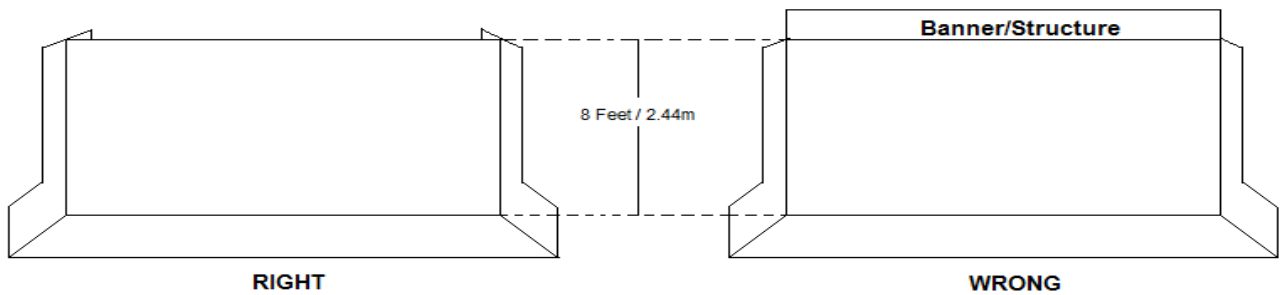
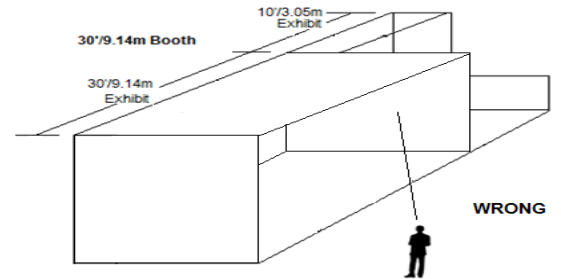
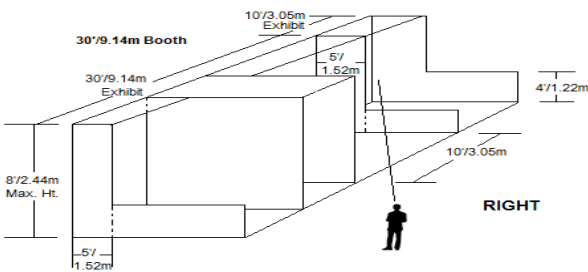
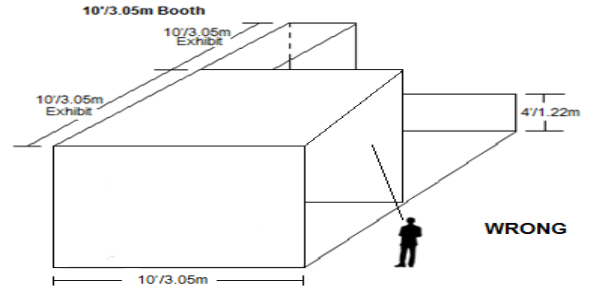
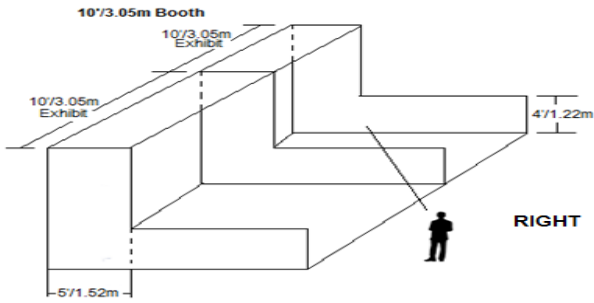

## TYPE B – PENINSULA BOOTH

All peninsula configurations must conform to the rules below. **THERE ARE NO SPLIT ISLANDS.**

### DEFINITION:

Four or more spaces back to back with an aisle on three sides.

### DEPTH:

All display fixture over 4'/1.22 m in height and placed within 10 lineal feet/3.05m of a neighboring exhibit, must be confined to the area within 5'/1.52m of the center line to avoid blocking the sightline from the aisle to the adjoining booth.

### HEIGHT:

Identification signs, canopies, and two-story exhibits will be permitted to a maximum height of 20'/6.1m provided written approval is received from Event Management at least 60 days prior to the show. Peninsula or Island Booths on Level 1 (booths J7200-J11300) cannot exceed a height of 12'. In addition, due to the ceiling height of 12 feet on Level 1, double decker booths are not permitted.

### INTENT:

When an exhibit in a peninsula booth configuration exceeds 8'/2.44m, it does not interfere with other exhibitors because it does not back up against another exhibitor's back wall. The extra height is often needed to permit the open walk through approach normally used in this type of location. The 20'/6.1m height limitation has been set to avoid undue competition between exhibitors to see who can go the highest or be seen the farthest with each negating the others' efforts.

Also, the 20'/6.1m height exhibits will fit into almost any exhibit hall, thus permitting each exhibitor to get maximum use of his exhibit. Peninsula or Island Booths on Level 1 (booths J7200-J11300) cannot exceed a height of 12'. In addition, due to the ceiling height of 12 feet on Level 1, double decker booths are not permitted.

Exhibitors adjoining peninsula exhibits are entitled to the same reasonable sightline from the aisle as they would expect if they were adjacent to an exhibitor with a standard booth.

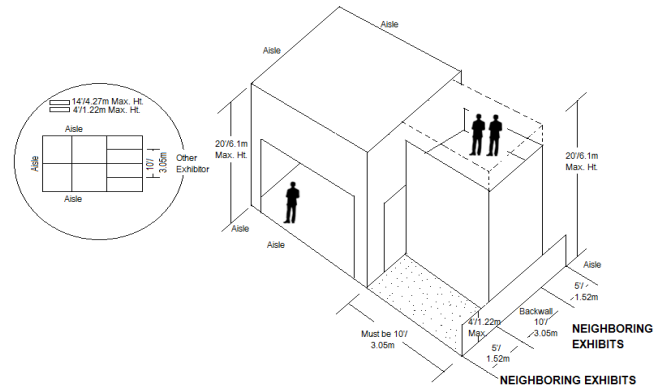

### PLEASE NOTE THE FOLLOWING:

- If any part of the booth does not comply with the above regulations, the exhibitor or EAC will be asked to make adjustments onsite as needed before the show opens.
- The back wall of the peninsula cannot have any copy or logos on the back wall.
- Please check the floor plan for columns and expansion joints as they are located throughout the exhibit hall and could bring additional expenses to the booth display. Contact AAPEX Event Management for location. AAPEX, Auto Care Association, MEMA, W.T. Glasgow Inc., Venetian Expo, Venetian Hotel, Caesars Forum, and FREEMAN are not responsible for any additional costs to the exhibitor or EAC due to column or expansion joint adjustments.
- Peninsula booths are normally "faced" towards the cross aisle. Any portion of the exhibit bordering another exhibitor's booth must have the back side of that portion finished and not carry identification signs or other copy that would detract from the adjoining exhibit.
- Peninsula or Island Booths on Level 1 (booths J7200-J11300) cannot exceed a height of 12'. In addition, due to the ceiling height of 12 feet on Level 1, double decker booths are not permitted.
- Space dimensions shown on floor plan are from center line of booth equipment such as side rails and/or back drape. Exhibit structures must be constructed to allow sufficient tolerance on each side for this equipment and for utility service at rear of booth.
- **IMPORTANT NOTE:** Exhibitor Appointed Contractors (EAC's), Booth Builders and General Contractors must submit their Architect Package (i.e. structure, electrical, plumbing etc.) to the Clark County Department of Building & Fire Prevention in order to obtain permits for double decker booths or those booths over 7,500 square feet. Refer to page 1 for more information.

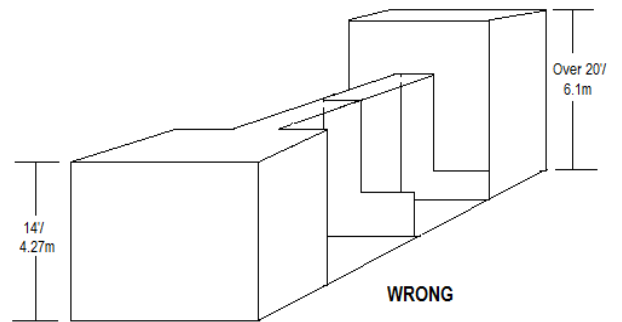
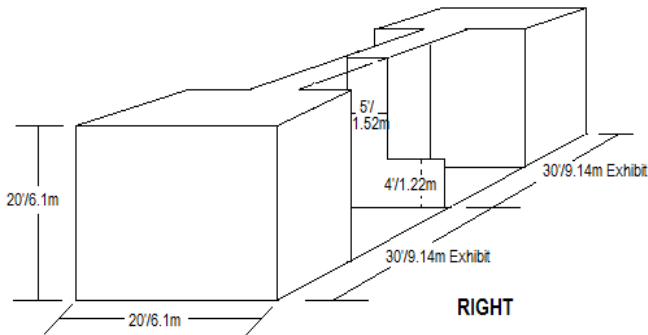

**NOTE:** Peninsula or Island Booths on Level 1 (booths J7200-J11300) cannot exceed a height of 12'. In addition, due to the ceiling height of 12 feet on Level 1, double decker booths are not permitted.

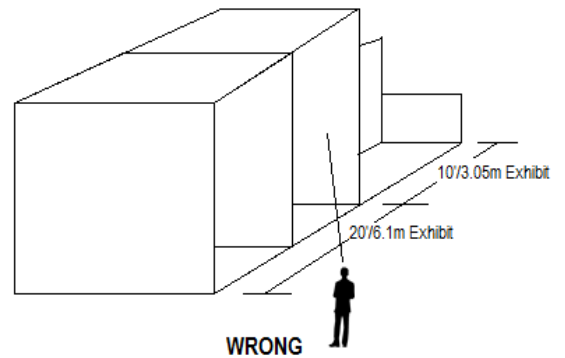
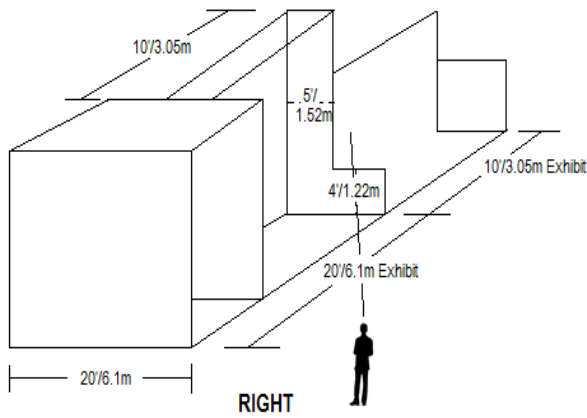

**NOTE:** Peninsula or Island Booths on Level 1 (booths J7200-J11300) cannot exceed a height of 12'. In addition, due to the ceiling height of 12 feet on Level 1, double decker booths are not permitted.

## TYPE C – ISLAND BOOTH

All island configurations must conform to the rules below. **THERE ARE NO SPLIT ISLANDS.**

**DEFINITION:**

Blocks of space with aisles on all four sides

**DEPTH:**

Since an island booth is automatically separated from the width of an aisle from all neighboring exhibits, full use of the floor space is permitted.

**HEIGHT:**

Identification signs, canopies, and two-story exhibits will be permitted to a maximum height of 20’/6.1m provided written approval is received from Event Management at least 60 days prior to Event.

**INTENT:**

When an exhibit in an Island booth configuration exceeds 8’/2.44m, it does not interfere with other exhibitors because it does not back up against another exhibitor’s back wall. The extra height is often needed to permit the open walk through approach normally used in this type of location. The 20’/6.1m height limitation has been set to avoid undue competition between exhibitors to see who can go the highest or be seen the farthest with each negating the others efforts. Also, the 20’/6.1m height exhibits will fit into almost any exhibit hall, thus permitting each exhibitor to get maximum use of the exhibit.

**PLEASE NOTE THE FOLLOWING:**

- If any part of the booth does not comply with the above regulations, the exhibitor or EAC will be asked to make adjustments onsite as needed before the show opens.

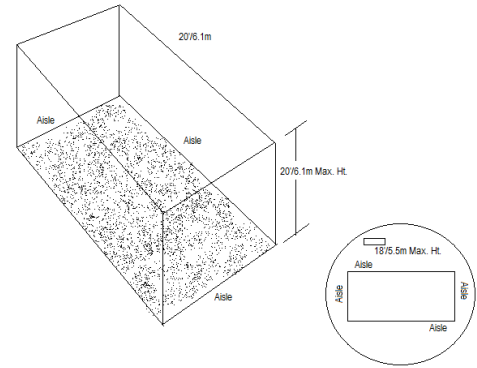

- Please check the floor plan for columns and expansion joints as they are located throughout the exhibit hall and could bring additional expenses to the booth display. Contact AAPEX Event Management for location. AAPEX, Auto Care Association, MEMA, W.T. Glasgow Inc., Venetian Expo, Venetian Hotel, Caesars Forum, and FREEMAN are not responsible for any additional costs to the exhibitor or EAC due to column or expansion joint adjustments.
- Peninsula or Island Booths on Level 1 (booths J7200-J11300) cannot exceed a height of 12’. In addition, due to the ceiling height of 12 feet on Level 1, double decker booths are not permitted.
- Depending on booth location, island exhibits over 20’ wide must have their design approved by Event Management prior to the start of the Event. If any portion of the exhibit blocks aisles behind them, an 8’ opening/exit may be required so there is a true aisle.
- Exhibitor Appointed Contractors (EAC’s), Booth Builders and General Contractors must submit their Architect Package (i.e. structure, electrical, plumbing etc.) to the Clark County Department of Building & Fire Prevention in order to obtain permits for double decker booths or those booths over 7,500 square feet. Refer to page 1 for more information.

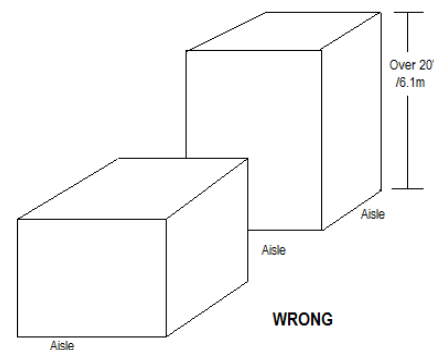
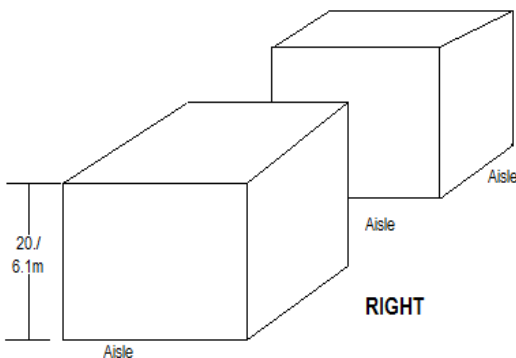

## HANGING SIGNS

### DEFINITION:

An exhibit component suspended above an exhibit of four or more standard units back to back with an aisle on at least three sides for the purpose of displaying graphics or identification.

### DEPTH:

All hanging signs must be set back at least 10 feet from the back wall of the booth. Please note: This does NOT apply to island configurations.

### INTENT:

Hanging signs, whether double faced or not, should be set back within the exhibitor's space so as not to detract from the overall impact of the exhibit that is directly adjacent.

### HEIGHT:

Hanging identification signs and graphics will be permitted to a maximum height of 24'/7.3m, provided written approval is received from Event Management at least 60 days prior to the Event.

### INTENT:

Hanging signs are part of the overall exhibit presentation and, therefore, must be treated as a component of the total exhibit configuration. All signs, whether suspended or attached to the exhibit fixture, will be permitted to a maximum height that corresponds to the appropriate exhibit configuration.

### SIZE:

Hanging signs and graphics will be permitted to a total length on each side of the exhibitor's space that does not exceed 50% of the corresponding dimension of the booth.

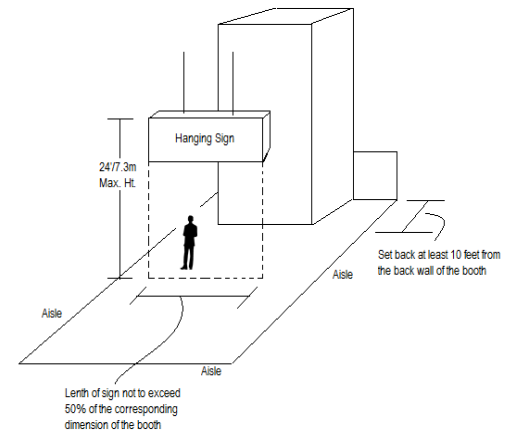

### INTENT:

The size and number of hanging signs must be limited in order to minimize the stress to the facility's ceiling structure on the part of any one exhibitor.

### STRUCTURAL INTEGRITY:

All hanging signs must have drawings available for inspection by Event Management, the installation and dismantling contractor, the exhibitor and governmental authority during the time the component is being hung, suspended and removed at the show site. This includes a signature or stamp of a reviewing structural engineer indicating that the stress points for hanging the sign have been properly engineered, and a signature of an authorized official of the exhibit building company indicating the structure is built in compliance with the details and specifications set forth on the drawings. (Note: exhibitors are encouraged to use lightweight materials in the construction of a hanging sign to eliminate excessive stress to the facility's ceiling structure.)

### PLEASE NOTE THE FOLLOWING:

If any part of the booth does not comply with the above regulations, you will be asked at Event site to make adjustments as needed before the Event opens.

Hanging signs are not permitted on Level 1 unless given written permission from the Venetian Expo.

## DEMONSTRATIONS OR ENTERTAINMENT

### REGULATION:

Do not place the demonstration areas on the aisle line of the exhibit if it is expected that many people will congregate at one time. Leave space within the exhibit area to absorb the majority of the crowd. Should spectators interfere with the normal traffic flow in the aisle or over flow into the exhibits of neighboring booths on each side or across the aisle, Event Management will have no alternative but to request that the exhibitor limit or eliminate the presentation.

### SOUND:

Exhibitors should police their own booth to be sure the noise level from any demonstrations or sound systems is kept to a minimum and does not interfere with others. Remember the use of sound systems or equipment producing sound is an exception to the rule, not a right. Event Management reserves the right to determine at what point sound constitutes interference with others and must be discontinued. Where there is a demonstration area located in an exhibitor's booth such as using any type of power tools or equipment that may cause a loud noise which will disrupt neighboring exhibitors, the exhibitor may want to build some type of Plexiglass enclosure around this area to contain the noise level.

### INTENT:

The aisles are the property of all the exhibitors therefore each exhibitor has the responsibility to assure proper flow of traffic through the entire show. When large crowds gather to watch a demonstration or entertainment and interfere with the flow of traffic down aisles or create excessive crowds in neighboring booths, this is an infringement on the other exhibitor rights. Aisles must not be obstructed at any time.

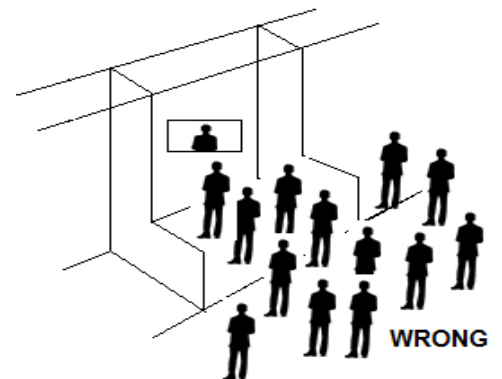
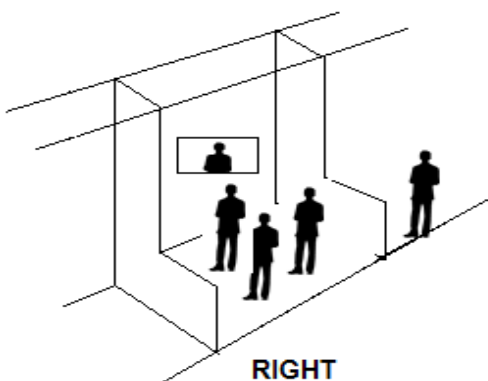



## LAS VEGAS CONVENTION AND VISITORS AUTHORITY REGULATIONS FOR ALL COVERED AND/OR DOUBLE-DECK EXHIBITS

1. Upper decks or covered areas are required to be limited to dimensions which do not exceed 1,000 sq. ft. in contiguous area.

**DEFINITIONS:**

**Upper Decks:** Any occupied second story or greater area which is accessible by an approved means of egress.

**Covered Areas:** Any area that covers the exhibit space and prevents the building fire sprinkler system from discharging water unobstructed to the floor. This will include single story exhibits with ceilings, upper deck exhibits, roofs, overhead lighting installations and any material hanging or installed overhead that is not recognized as acceptable for use under fire sprinkler systems by fire code.

**Contiguous:** Any area or combination of areas which are not separated by a clean 10 ft. fire break. This measurement is made horizontally.

**Fire Break:** A clear, non-combustible space at least 10 feet in width surrounding the exhibit or exhibit space on all sides.

**Floor Covering:** All exhibit space must be carpeted or have a fire-resistant covering. Any floor covering left adhered to the exhibit floor must be removed at the exhibitors' expense.

**Means of egress:** An approved stairway or ramp constructed to the specifications of the code used for access and exiting.

2. If an additional Upper Deck or Covered contiguous area is required in excess of 1,000 sq. ft. without the use of a fire sprinkler system, a system shall be installed under the entire area and every level of a multi-level exhibit.
3. If additional Upper Deck or Covered area is required in excess of 1,000 sq. ft. without the use of a fire sprinkler system, contiguous areas limited to 1,000 sq. ft. may be separated by a minimum 10-foot fire break on all sides.

The fire break shall be void of any combustible displays, furniture or other material which could abet transfer of fire from one area to the other.

**Exception:** The fire break may be spanned by a single bridge, catwalk or structure that shall not exceed 48

inches in width and shall be constructed of fire resistant on non-combustible materials.

4. Exhibitor Appointed Contractors (EAC's), Booth Builders and General Contractors must submit their Architect Package (i.e. structure, electrical, plumbing etc.) to the Clark County Department of Building & Fire Prevention in order to obtain permits for double decker booths or those booths over 7,500 square feet. The Architect Package must include a signature or stamp of a reviewing structural engineer confirming that the double decker booth has been properly engineered, as well as a signature of an authorized official of the exhibit building company indicating that the structure is built in compliance with the details and specifications set forth on the drawings. For questions, or to schedule an inspection, contact the Clark County Department of Building & Fire Prevention at 702-455-8040 or email [inspchedule@ClarkCountyNV.gov](mailto:inspchedule@ClarkCountyNV.gov).

In addition, temporary buildings or structures, such as reviewing stands, grandstands, sheds or other miscellaneous structures, shall not require a permit, construction document approval or building permit issuance provided such structures are not erected or used for longer than six (6) months and meet all of the following criteria: a) single story, b) total occupant load of 1,000 persons or less and c) covering a maximum area of 7,500 square feet.

5. Upper Deck of Covered areas shall not have any additional deck, ceiling or covering installed above for any purpose unless a fire sprinkler system is installed in each level of the exhibit.
6. Upper Deck areas that are greater than 300 sq. ft., of which will occupy more than 10 persons shall have at least two remote means of egress. Remote is defined such that the means of egress shall be placed at a distance from one another, not less than one-half the length of the maximum overall diagonal dimension of the area to be served.
7. Means of egress shall be of an approved type and constructed to the requirement of the code. Spiral stairs are not allowed. Spiral stairways are not an approved means of egress for areas occupied by the public, visitors or the clientele.

8. Exhibits with Upper Decks, Covered or Roofed areas exceeding 300 sq. ft. in size will require the installation of batter-operated smoke detectors. Any covered area that is also enclosed will require the installation of batter-operated smoke detectors regardless of the size of the area. All smoke detectors will emit an audible alarm that can be heard outside of the area and must be installed in accordance with NFPA 72. Operation of smoke detectors must be certified after installation.
9. Any multi-level exhibit or exhibit with 1,000 sq. ft. of Upper Deck or Covered areas must have a booth plan submitted to the LVCVA Fire/Safety Department for approval prior to the exhibit coming on the LVCVA Convention Center or Venetian Expo property.

## OPERATION AND CONDUCT

1. **Regulation and Restriction.** Event Management reserves the right to regulate and/or restrict exhibits to a reasonable noise level. Use of sound motion pictures and tape recorders will be permitted, where appropriate to the display, provided sound is maintained at not more than 85dB peaks, on the C weighted scale as measured on a Scott Instrument Lab Type 452 Sound Level Meter (ANSI Type 2), on the "SLOW" meter position, in any and all adjacent exhibit areas. AAPEX reserves the right to restrict Exhibitor's use of sound and other devices which may interfere with the best interest of AAPEX as a whole. Event Management is authorized and empowered to disconnect the supply of electricity to any Exhibitor that exceeds said Sound Level maximum, without any liability to said Exhibitor.

Event Management also reserves the right to regulate and/or restrict exhibits to suitable methods of operation and display of materials. These restrictions include any product and power equipment in a demonstration that may cause a distraction to any neighboring Exhibitor that cannot conduct business in its exhibit area because of the noise or other factor. If for any reason an exhibit and/or its contents are deemed objectionable by Event Management, the exhibit shall be subjected to removal at Exhibitor's sole expense. This reservation includes persons, things, conduct, printed matter, signs, or any item of poor character which in the sole judgment of Event Management is detrimental to the Event. In the event such an amendment or restriction is enforced, Event Management shall have no obligation to refund exhibit space rental fees or exhibit equipment rental fees. Exhibitor hereby expressly waives any right and all claims, actions or demands for damage, costs and expenses, including legal fees, against the Indemnified Parties for such amendment or removal. **Please note:** An Exhibitor may not use or reference a competitor's product in a demonstration or any type of comparisons.

2. **No Retail Sales.** Exhibitors are not permitted to sell products for delivery at the Event. Orders may be taken for future delivery only.
3. **Prohibited Displays.** Exhibitor shall not exhibit, offer for sale, or provide advertising or literature concerning products or services not manufactured, represented, or exclusively distributed by them. No animals, reptiles, birds, rodents, or insects may be used as part of any exhibit or display. Robots may be used only upon the

written consent of Event Management, and must be confined to the exhibit space rented. No helium balloons are permitted within the exhibit area. Exhibitors shall not permit exhibitions, raffles, donations or other promotional measures that require members or guests to be present at a specified location and time and all unusual promotion plans must be approved by Event Management no later than July 30, 2021.

If, in Event Management's judgment, any feature in exhibit space proposed by an Exhibitor, does or may involve risk of harm or danger to Event participants, such feature may be prohibited by Event Management or may be subjected to additional requirements and safety precautions as determined by Event Management.

No Exhibitor shall foster or conduct any event during the AAPEX Exhibit hours, other than a luncheon within the Event venue, not to exceed one and one-half hours, which would take attendance from the exhibit floor.

Exhibitors/NEMs are not authorized to hold functions off-site and provide private transportation to those functions and trade events from AAPEX during exhibit hours.

4. **Safety and Security.** Exhibitors are prohibited from possessing any weapons of any kind while in or on AAPEX facilities. For purposes of this prohibition, AAPEX facilities means all exhibit halls and spaces, whether indoor or outdoor, but does not include parking facilities used by Exhibitors solely for parking, to the extent storage or possession of a weapon in a vehicle is permitted by the regulations applicable to such facilities and by applicable law. Weapons include, guns of any type, knives other than standard box cutters and the like used for exhibit set up and tear down, mace, explosives or any item with the potential to inflict harm that has no common exhibit-related purpose. This list is illustrative only, and not exhaustive. Event Management reserves the right to expel any Exhibitor that Management believes, in its sole discretion, may pose a safety or security risk to him or herself or others and/or is acting in a manner intended to harass, annoy, threaten, or intimidate other Exhibitors, attendees, Event Management, staff, or contractors.
5. **Outboarding/Suitcasing Prohibited.** Suitcasing and Outboarding are expressly prohibited.

“Suitcasing” occurs when companies or persons attending the Event as attendees and not as

Exhibitors “work the aisles” soliciting business from other attendees or Exhibitors. “Outboarding” occurs when companies or individuals, including Exhibitors, set up events or activities at locations other than the Event venue that encourage attendees of the Event to either leave the Event or to not attend authorized Event activities. Therefore, any company or person (a) holding an exhibit, demonstration or display in a Clark County, NV hotel, suite, meeting room, or other non-official Event venue during AAPEX, or (b) engaging in suitcasing, will face sanctions by Event Management. Sanctions may include loss of seniority privileges, a ban from the current and future Events and other sanctions as deemed appropriate by Event Management.

6. **Exhibit Obstructions.** Exhibitors are not allowed to obstruct the view, occasion injury or adversely affect the displays of other Exhibitors. This includes demonstrations.

**PLEASE NOTE:** Depending on booth location, island exhibits over 20’ wide must have their design approved by Event Management prior to the start of the Event. If any portion of the exhibit blocks aisles behind them, an 8’ opening/exit may be required so there is a true aisle.

7. **Exhibit Personnel.** All personnel, including models/demonstrators, must be properly clothed/dressed appropriately at all times and must confine their activities to the contracted exhibit space. Personnel may not enter the exhibit space of another Exhibitor without permission from that Exhibitor and at no time may anyone enter an exhibit space which is not staffed. If Exhibitor personnel enter the exhibit space of another Exhibitor, without permission from that Exhibitor, such Exhibitor is subject to penalties for a rules violation, including a loss of all or a portion of its seniority points.
8. **Use of Carrying Devices.** Dollies, carts and other rolling devices will not be permitted on the exhibit floor during exhibit hours without the prior written consent of Event Management.
9. **Damages and Insurance.** Exhibitor is responsible for all damage to property caused by Exhibitor personnel. Should such damage occur, Exhibitor is liable to the owner of the damaged property. Exhibitor must carry insurance for loss of product or damage of product while exhibiting at AAPEX. AAPEX is not responsible.

Exhibitor shall be liable for, and shall insure against, all injuries or damages caused by the acts or omissions of the exhibitor or its employees, representatives, servants, agents, licensees, invitees, patrons, guests or contractors. Exhibitor agrees to obtain and furnish to Event Management at least thirty (30) days prior to set-up a certificate of insurance showing that there is in effect a policy of a minimum of \$1,000,000 combined single limit bodily injury and broad form property damage coverage, including broad form contractual liability in which the Indemnified Parties Interface Group, Nevada, Inc., Interface Group - Massachusetts, Inc., and the Las Vegas Venetian Expo, Inc. and their directors, officers and employees as additional insureds and Banc One Mortgage Capital Markets, LLC, as administrative agent and as collateral agent are each named as additional insureds. Exhibitor shall obtain workers compensation insurance, and provide proof of same to Event Management, for all Exhibitor’s employees.

The Exhibitor is responsible for any and all demands on account of any injury or death, or damage to property occurring in or upon any portion of the Event venue Expo leased or used by Exhibitor which are caused by the acts or omissions of Exhibitor, or its employees, representatives, servants, agents, licensees, invitees, patrons, guests, or contractors. Exhibitor is also solely responsible for any injuries or damages sustained or caused by it in connection with AAPEX, whether or not they occur at the Event venue. This includes, but is not limited to, booth construction, booth set-up, travel to or from AAPEX, activities of the Exhibitor’s employees or third parties subject to the supervision of Exhibitor, or any other activities carried on in connection with AAPEX. Exhibitor shall defend, indemnify and hold harmless the Indemnified Parties from and against any and all claims, demands, actions, causes of actions, penalties, judgments, and liabilities of every kind and description (including court costs and reasonable attorneys’ fees) for injury to and death of persons, and damage to and loss of property which are caused by, arise from or grow out of Exhibitor’s use or occupancy of the premises or from any breach by Exhibitor of any condition of this Agreement, or from any act or omission of Exhibitor, or its employees, representatives, servants, agents, invitees, patrons, guests, licensees, or contractors. The Exhibitor agrees to make no claim for any act or omission of Event Management taken in accordance with the Exhibitor Regulations.

10. **Advertising.** Exhibitor shall not, without the prior written consent of Event Management, distribute or permit to be distributed any advertising matter,

literature, souvenir items or promotional materials in or about the exhibit areas except from its own allotted exhibit space. The use of the AAPEX name and logo (including anything affiliated with AAPEX, Event Management, AAIW, or Automotive Aftermarket Industry Week) and any licensed products are strictly prohibited without the express prior written consent of Event Management and/or Event Owners (MEMA/AASA and Auto Care Association). This includes, but not limited to, Exhibitor, supplier and contractor publications.

11. **Food and Beverages.** Alcoholic beverages may not be served within an Exhibitor's exhibit space without written prior written permission from Event Management. Exhibitors receiving permission to serve alcoholic beverages must provide a certificate of insurance for Liquor Liability naming Event Management as additional insured. Alcoholic beverages may not be served during exhibit set-up or tear-down under any conditions. Exhibitors must have approval of Event Management before dispensing or distributing any food, snacks or beverage items within an Exhibitor's exhibit space. Any food and/or snack and/or beverage and/or use of food equipment within an Exhibitor's exhibit space must be provided by the Venetian Expo Catering Department. Preparation of food within the exhibit areas is prohibited.
12. **Photography/Video Recording.** With today's new technology it is increasingly more challenging to monitor camera use on the show floor. Also given that AAPEX is working to increase social media outreach, Event Management asks that all Exhibitors monitor photography within their booths. Event Management will have signs available for Exhibitors to display that state "No Photos Allowed". These signs will be available at the Event Management Office, located in Room 305 of the Venetian Expo.

Please contact Event Management for any issues with an attendee at the Show regarding photos in the booth. If an Exhibitor has signage or has made it clear to attendees that they are not allowed to take photos in their booth or of their products, then Event Management has the right to confiscate film or other media from any type of camera from users.

Press/Media must obtain a permit at the Event Management Office, photographs must be authorized by the Exhibitor, and will not be affected by the no photography signs. Event Management is authorized to record and use audio/visual materials and photographs taken at AAPEX.

Exhibitors are prohibited from filming or photographing any portion of the Event for commercial purposes without the express prior written consent of Event Management. Event Management may condition its consent on an Exhibitor becoming an authorized vendor pursuant to a written agreement required by Event Management, which includes, without limitation, the requirement that a commission fee be paid to Event Management.

13. **Drones & Personal Mobility Device Policy.** Drones/unmanned aerial vehicles (UAVs), hoverboards, and personal mobility devices—such as segways, skateboards, skates and scooter (motorized or foot-powered) are NOT allowed at AAPEX. No exceptions, other than ADA-approved mobility devices with advance approval by Event Management. FAA regulations require UAVs/Drones to be flown at least 5 miles from any active airport. The Event venue is less than 5 miles from McCarran International Airport. Any of these items reported or found at the Event will be confiscated until the Event ends on Friday, November 8, at 8:00 pm.
14. **Authority.** Event Management is the final authority on all matters relating to operation and conduct.
15. **Celebrity Appearances/Giveaways.** Exhibitors may have a celebrity in the booth signing autographs, providing that the line of attendees does not block neighboring Exhibitors.

The Exhibitor must provide security in the aisle to prevent any type of traffic problems and the Exhibitor with the celebrity is responsible for any and all charges incurred for traffic control in the aisles around its booth. This regulation also pertains to any type of giveaways being handed out in the booth that may block neighboring Exhibitors' booths.

If an Exhibitor displays products that are not manufactured by the Exhibitor, but the Exhibitor has the sole and exclusive right to sell the product for the entire United States, the Exhibitor must provide Event Management documentation to substantiate this criteria. Distributors are required to submit a letter of appointment from the manufacturer on the manufacturer's letterhead. Products must be packaged and marketed under the Exhibitor's trade style or brand name and be supported by current cataloging and price sheets.

16. **Demonstrations.** An Exhibitor may not use or reference a competitor's product in a demonstration or any type of comparison.